

NACELLE VERTICALE ELECTRIQUE 10 M



105 VJR

- 
Hauteur de travail maxi
10.30 m
- 
Charge maxi
250 kg*

*2 personnes maximum
- 
Déport maxi
3.30 m
- 
Poids du matériel
3.28 t



CARACTÉRISTIQUES

Constructeur	MANITOU
Modèle	105 VRJ
Energie	Batterie-Electrique
Dimensions (L x l x h)	2.81 x 0.99 x 1.99 m
Dimensions Panier (L x l)	1.05 x 0.99 m
Rayon de braquage int /ext	0.52 / 2.02 m
Rotation tourelle	350°
Garde au sol	85 mm
Nombre de personnes	2

unité : mm

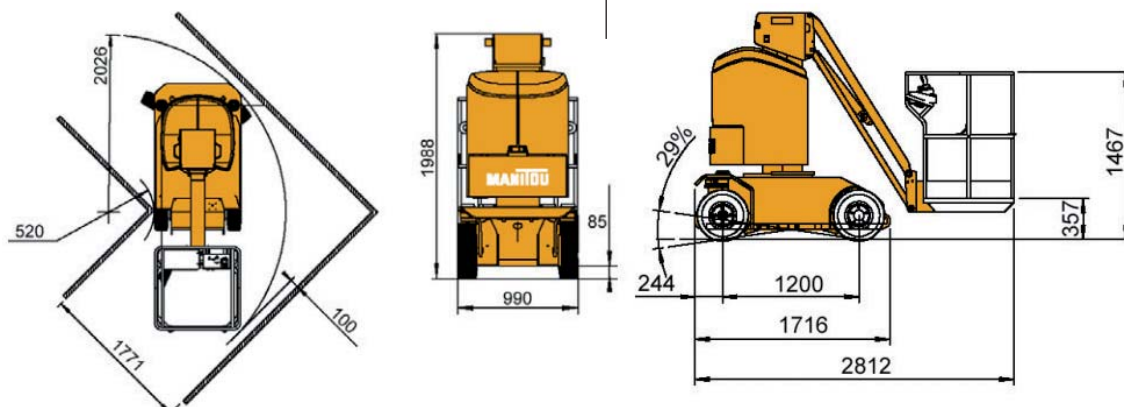

Document non contractuel

105 VJR

ABAQUES

