

S 45



Hauteur de travail

15.50 m



Déport maxi

11.20 m



Charge maxi

227 kg



Nombre de personnes max

2



CARACTÉRISTIQUES

Constructeur	GENIE
Capacité réservoir carburant	125 L
Modèle	S 45
Dimensions (L x l x h)	8.50 x 2.30 x 2.50 m
Dimension du panier (L x l)	1.80 x 0.76 m
Rotation du panier	160°
Rayon de braquage int/ext	2 / 4.80 m
Poids	6.70 t
Roues motrices	4 roues motrices
Bras pendulaire	oui
Niveau sonore	70 dB

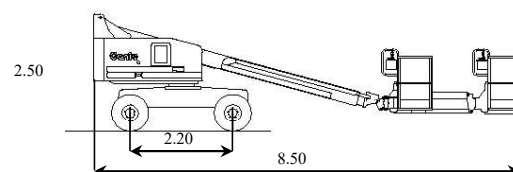
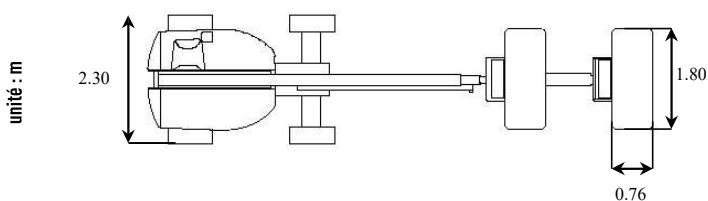

S 45

ABAQUES

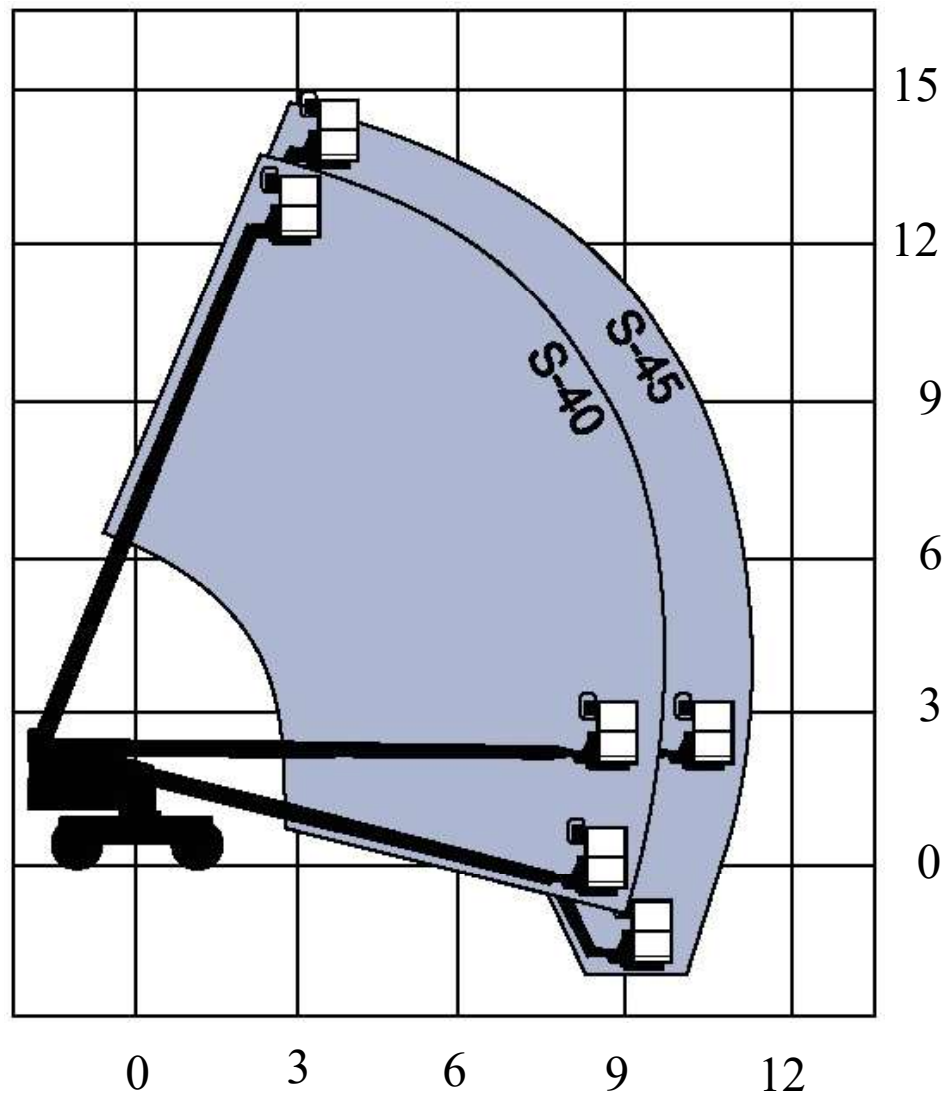

unité : m

Document non contractuel