

NACELLE VERTICALE ELECTRIQUE 11 M



AWP 30 DC



Hauteur de travail maxi

11.10 m



Charge maxi

159 kg



Poids du matériel

370 kg



CARACTÉRISTIQUES

Constructeur	GENIE
Modèle	AWP 30 DC
Energie	Batterie-Electrique
Dimensions (L x l x h)	1.30 X 0.74 X 1.98 m
Dimensions Panier (L x l)	0.66 X 0.66 m
Niveau sonore	80 dB
Nombre de personnes	1

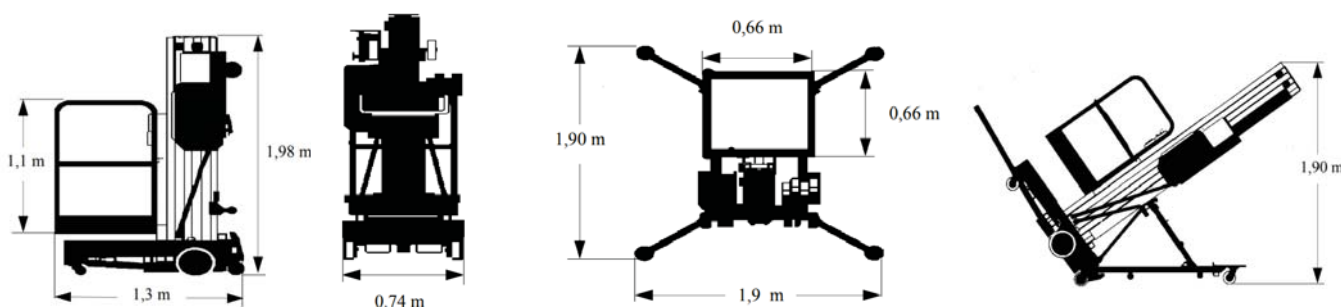

Document non contractuel