





**M 26**

- 
Hauteur de levage maxi
5.40 m
- 
Capacité de levage
2.60 t
- 
Energie
GNR
- 
Poids du matériel
5.42 t



**CARACTÉRISTIQUES**

Marque	MANITOU
Modèle	M26
Moteur	PERKINS 1004-42
Motricité	4 Roues motrices
Vitesse	28 km/h
Capacité du réservoir carburant	85 L
Dimensions (L x l x h)	4.83 x 2.10 x 2.93 m
Rayon de braquage	4.09 m
Garde au Sol	46.5 mm
Effort de traction	1300 daN (à vide)
Dimensions Fourches (L x l x e)	1.2 x 0.12 x 0.04 m

unité : mm

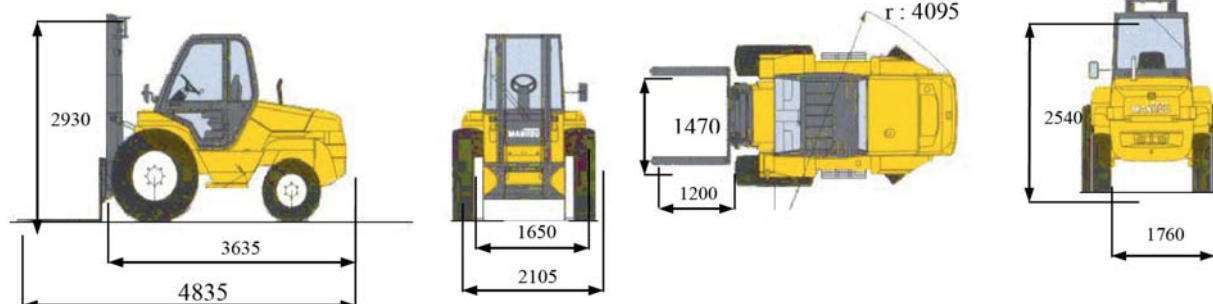

Document non contractuel

M 26

ABAQUES

Abaque de Charge M26-4 Mât à Glissière

